

# Ultra-Filter

## DF 0035 - DF 1100

Filter with Economizer/ Economizer and pneumatic/ electronic drain resp. plug for application of different element types for the industrial processing of compressed air and gases.

### Product description:

The filters Ultra-Filter DF are intended for the processing of compressed air or other gases in different areas of applications.

The intelligent overall concept of the filter unites the following characteristics:

- high performance
- efficiency
- compactness
- easy of use
- flexibility
- safety

Validated performance data acc. to ISO 12500-1 for reliable achievement of compressed air quality suitable to the application acc. to ISO 8573-1.

Besides energy cost savings by the filter design, the use of the Economizer offers further saving achievements through timely replacement of the used filter elements. The most cost-effective replacement time for the filter element is calculated and LEDs then signal that the "filter exchange" is necessary.

With 9 sizes the Ultra-Filter covers the performance range from 35 to 1100 m<sup>3</sup>/h flow rate and hence conventional compressor capacities between 2 and 120 KW.



Version Superplus



Filter combination with adapter

Three versions are available:

#### Standard

(type with float condensate drain and Economizer / with element A with plug, without Economizer).

#### Plus

(float condensate drain and Economizer / with element A with plug and Economizer).

#### Superplus

(level-controlled condensate drain UFM-D and Economizer).

A selection of appropriate filter grades by filter element types **S, M, V, B, P, A** ensure that the right product for the filtration task is always available to the user.

The filter housing design allows an easy replacement of the filter element. The filter bowl is rotated slightly via a bayonet lock and can be removed together with the filter element. For this a installation height of only a few centimetres of ground clearance is necessary.

## Ultra-Filter DF 0035 - DF 1100

### Technical Data

Features:	Benefits:
Validated performance data acc. to ISO 12500-1	Reliable achievement of compressed air quality acc. to ISO 8573-1
Intelligent overall concept	Flow range, filtration grades, efficiencies and available options perfectly meet requirements of industrial air purification
Flow-optimised filter housing and filter element design	Low pressure losses, thereby saving of energy costs
Bayonet fixing between filter head and filter bowl; element can be removed together with filter bowl; filter head with integrated differential pressure indicator can be rotated	Easy to use construction - simplified filter replacement; simple installation and assembly
Little installation height for the filter element exchange, differential pressure indicator integrated in filter head	Compact, space-saving construction - installation within smallest space possible
Changing the coding clip inside the filter cover allows the filter element to be rotated and thus change the flow direction	High flexibility - filters can be either used as coalescence filters or particulate filters
Filter cannot be opened under pressure due to bayonet lock	High safety during operation
Filter housings immersion-laquererd on the inside and outside surface	Ensures long-term corrosion protection, in particular against aggressive condensates

Options:	
Econometer	Mechanical differential pressure indicator
Economizer	Differential pressure indicator for the determination of the most economical time for replacement of the filter element; Possibility of remote data transmission
KA ½ / UFM-P	Float drain, pneumatically
UFM-D	Electronic level-controlled condensate drain without compressed air losses
UFZ	Time-controlled condensate drain
S	Plug
Wall bracket	Distance to the wall gradelessly adjustable (except DF-0035)
Connection adapter	Intelligent adapter solution for filter combination
Filter elements	V / M / S (coalescence filter) P / B (Pre-filter / particulate filter) A (activated carbon filter)

**Ultra-Filter DF - S 0035 Z U**

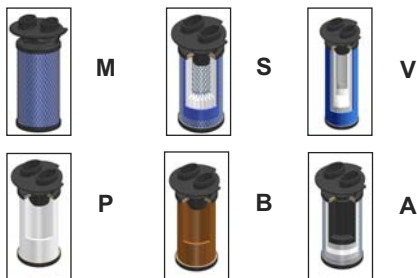

0035  
0070  
0120  
0210  
0320  
0450  
0600  
0750  
1100

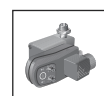
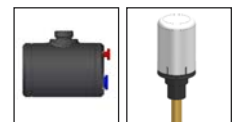
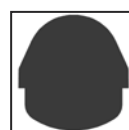

P-filter Particle filter	Initial differential pressure : 0,15 bar 1 Efficiency : 100% related to 25 µm
B-filter Particulate filter	Initial differential pressure : 0,12 bar 1 Efficiency : 100% related to 25 µm
A-filter Activated carbon filter	Initial differential pressure : 0,15 bar 1 Residual oil content : 0,003 mg/m³ 3
V-filter Coalescence filter	Initial differential pressure : 0,11 bar 1 Residual oil content: < 0,2 mg/m³ 2
M-filter Coalescence filter	Initial differential pressure : 0,11 bar 1 Residual oil content : < 0,02 mg/m³ 2
S-filter Coalescence filter	Initial differential pressure : 0,13 bar 1 Residual oil content : < 0,01 mg/m³ 2

1 related to nominal performance at 7 bar, dry condition  
2 related to an inlet concentration of 3 mg/m³  
3 when upstream connected a M- or S-filter

## Ultra-Filter Standard (DF 0035 MK - DF 1100 MK)

Pos.	Pcs.	Description
1	1	Filter head
2	1	Lower housing bowl
3	2	Wall bracket (option)
4	1	Econometer
5 DF 0035 - DF 0750	1	Internal automatic drain KA 1/2
6 DF 1100	1	External automatic drain UFM-P

Materials	
Filter housing	Aluminium die cast
Econometer	Polymer
Float drain	Polymer / aluminium mold cast
Sealings	Viton

Max. operating pressure	16 bar
Test pressure	22.9 bar
Perm. operating temperature	+1°C / +65°C

Classification acc. to 97 / 23 / EG for fluids group 2	
DF 0035 - DF 0320	Art. 3, par. 3
DF 0450 - DF 1100	Cat. I

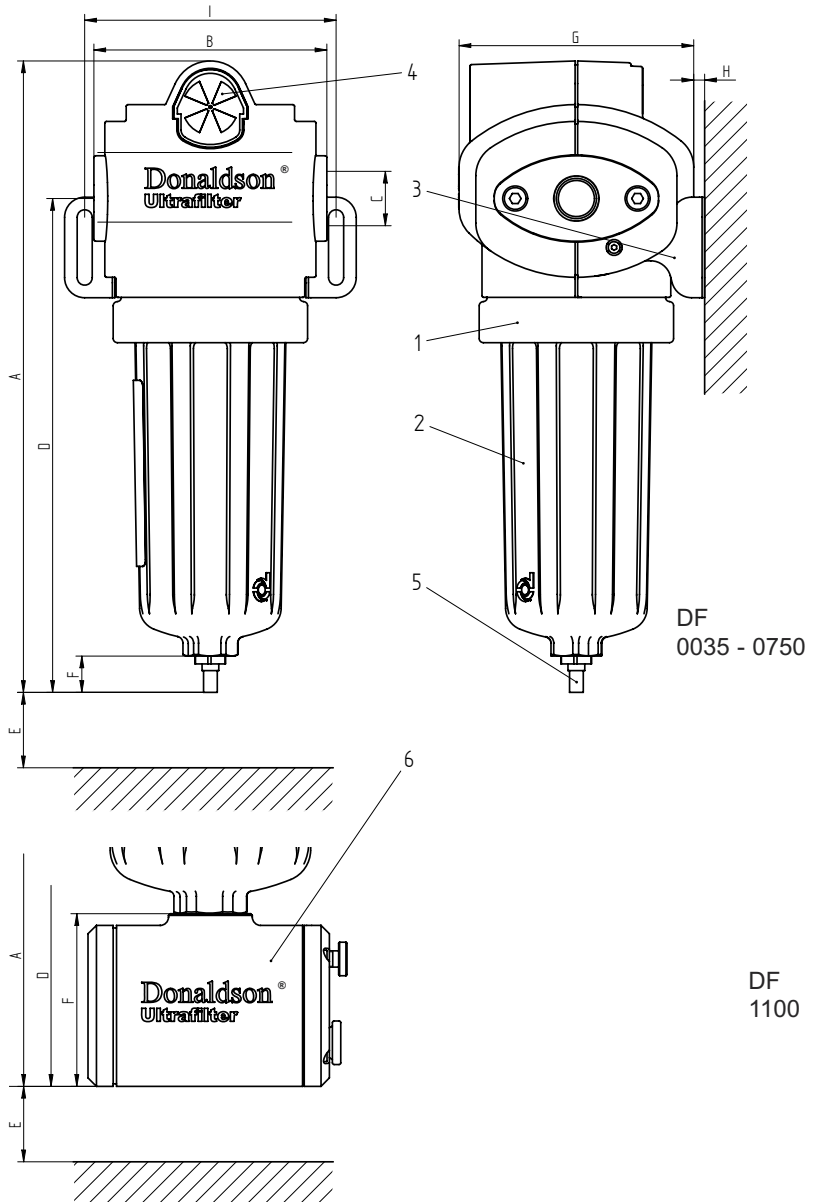

Size housing/element	Flow rate* m <sup>3</sup> /h	Volume (l)	Weight** (kg)	A mm	B mm	C	D mm	E mm	F mm	G mm	H min./ max. mm	I mm
0035	35	0,20	0,5	255	76	G ¼	185	100	27	85	5	84
0070	70	0,40	0,9	297	103	G ⅜	222	115	27	107	5 / 34	107
0120	120	0,50	1,0	340	103	G ½	265	150	27	107	5 / 34	107
0210	210	1,15	2,0	382	139	G ¾	300	180	27	140	5 / 53	150
0320	320	1,50	2,2	442	139	G 1	360	250	27	140	5 / 53	150
0450	450	5	5,2	585	190	G 1¼	487	250	27	203	5 / 73	190
0600	600	5	5,2	585	190	G 1½	487	250	27	203	5 / 73	190
0750	750	5	5,2	585	190	G 2	487	250	27	203	5 / 73	190
1100	1100	6	7,2	765	190	G 2	665	250	103	203	5 / 73	190

\* Nominal flow at 7 bar g, m<sup>3</sup>/h related to 1 bar abs. and 20°C

\*\* without filter element

## Ultra-Filter Plus (DF 0035 ZK - DF 1100 ZK)

Pos.	Pcs.	Description
1	1	Filter head
2	1	Lower housing bowl
3	2	Wall bracket (option)
4	1	Economizer
5 DF 0035 - DF 0750	1	Internal automatic drain KA 1/2
6 DF 1100	1	External automatic drain UFM-P

Materials	
Filter housing	Aluminium die cast
Economizer	Polymer
Float drain	Polymer / aluminium mold cast
Sealings	Viton

Max. operating pressure	16 bar
Test pressure	22.9 bar
Perm. operating temperature	+1°C / +65°C

Classification acc. to 97 / 23 / EG for fluids group 2	
DF 0035 - DF 0320	Art. 3, par. 3
DF 0450 - DF 1100	Cat. I

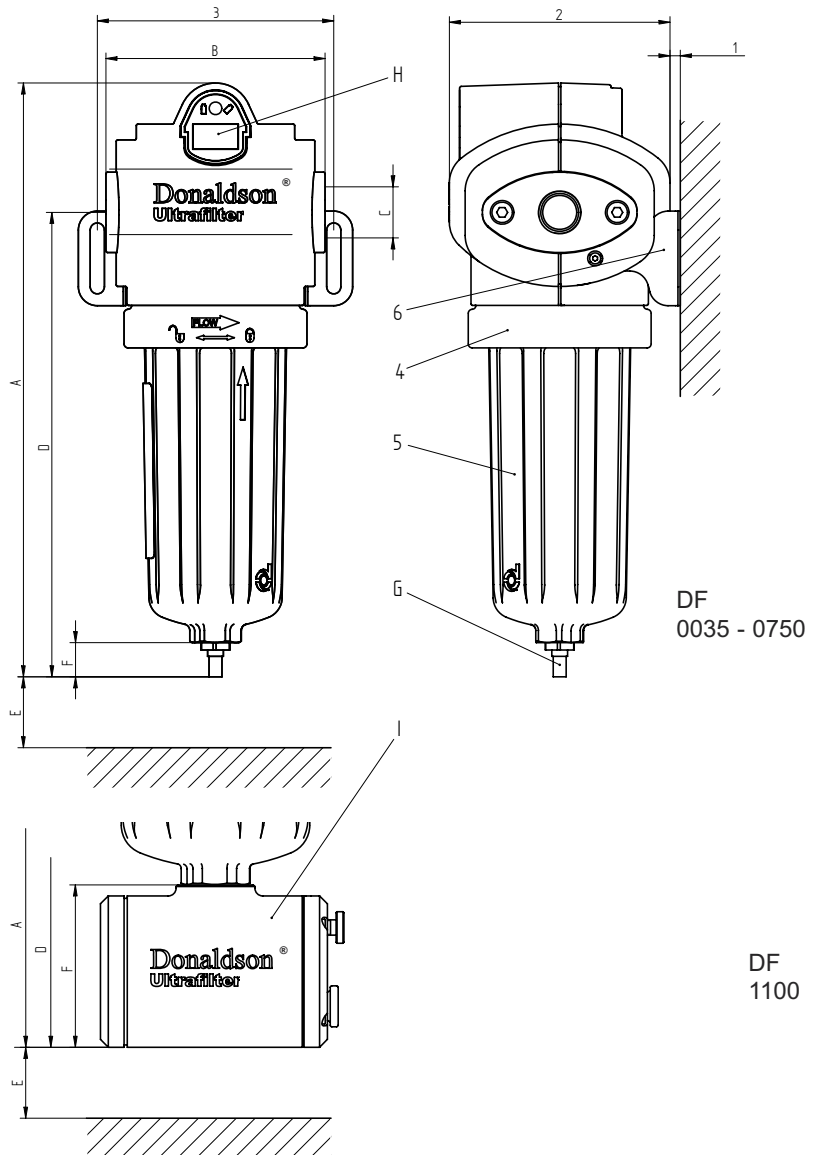

Size housing/element	Flow rate* m <sup>3</sup> /h	Volume (l)	Weight** (kg)	A mm	B mm	C	D mm	E mm	F mm	G mm	H min./ max. mm	I mm
0035	35	0,20	0,5	255	76	G 1/4	185	100	27	85	5	84
0070	70	0,40	0,9	297	103	G 3/8	222	115	27	107	5 / 34	107
0120	120	0,50	1,0	340	103	G 1/2	265	150	27	107	5 / 34	107
0210	210	1,15	2,0	382	139	G 3/4	300	180	27	140	5 / 53	150
0320	320	1,50	2,2	442	139	G 1	360	250	27	140	5 / 53	150
0450	450	5	5,2	585	190	G 1 1/4	487	250	27	203	5 / 73	190
0600	600	5	5,2	585	190	G 1 1/2	487	250	27	203	5 / 73	190
0750	750	5	5,2	585	190	G 2	487	250	27	203	5 / 73	190
1100	1100	6	7,2	765	190	G 2	665	250	103	203	5 / 73	190

\* Nominal flow at 7 bar g, m<sup>3</sup>/h related to 1 bar abs. and 20°C

\*\* without filter element

## Ultra-Filter Superplus (DF 0035 ZU - DF 1100 ZU)

Pos.	Pcs.	Description
1	1	Filter head
2	1	Lower housing bowl
3	2	Wall bracket (option)
4	1	Economizer
5 DF 0035 - DF 1100	1	Condensate drain UFM-D03

Materials	
Filter housing	Aluminium die cast
Economizer	Polymer
Float drain	Aluminium / fiber-glass reinforced plastic
Sealings	Viton

Max. operating pressure	16 bar
Test pressure	22,9 bar
Perm. operating temperature	+1°C / +65°C

Classification acc. to 97 / 23 / EG for fluids group 2	
DF 0035 - DF 0320	Art. 3, par. 3
DF 0450 - DF 1100	Cat. I

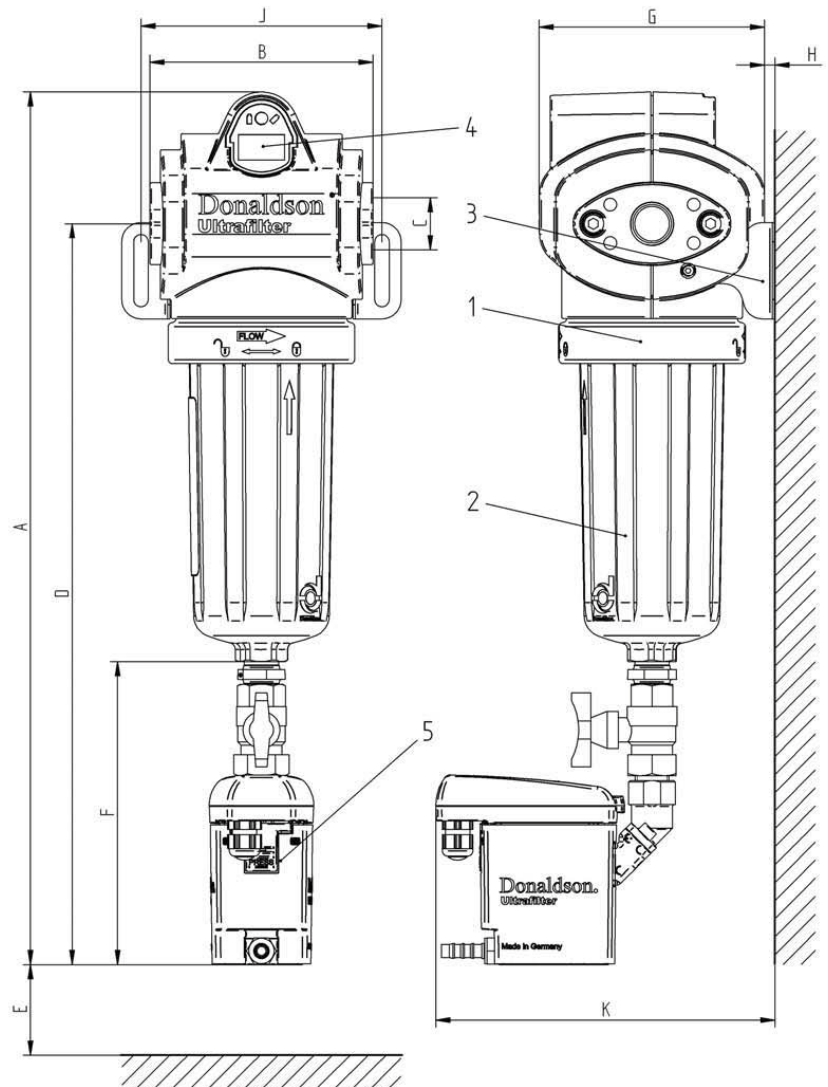

Size housing/element	Flow rate* m <sup>3</sup> /h	Volume (l)	Weight** (kg)	A mm	B mm	C mm	D mm	E mm	F mm	G mm	H min./ max. mm	J mm	K mm
0035	35	0,20	1,6	405	76	G 1/4	340	100	180	85	5	84	182
0070	70	0,40	2,0	450	103	G 3/8	375	115	180	107	5 / 34	107	193
0120	120	0,50	2,1	499	103	G 1/2	420	150	180	107	5 / 34	107	193
0210	210	1,15	3,1	535	139	G 3/4	453	180	180	140	5 / 53	150	210
0320	320	1,50	3,3	595	139	G 1	513	250	180	140	5 / 53	150	210
0450	450	5	6,7	740	190	G 1 1/4	640	250	180	203	5 / 73	190	242
0600	600	5	6,7	740	190	G 1 1/2	640	250	180	203	5 / 73	190	242
0750	750	5	6,7	740	190	G 2	640	250	180	203	5 / 73	190	242
1100	1100	6	6,9	840	190	G 2	740	250	180	203	5 / 73	190	242

\* Nominal flow at 7 bar g, m<sup>3</sup>/h related to 1 bar abs. and 20°C

\*\* without filter element